

Standard Accessories

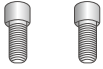

M8 x 16 Bolt x 2



Peep Hole Copper Terminal 16-8 x 2

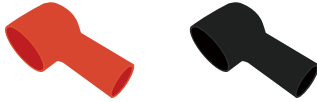

Pipe Type Terminal Insulating Cap One Red And One Black

You can use it this way

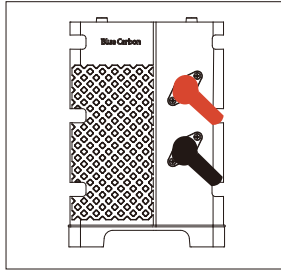

PRODUCT MANUAL

LITHIUM ION BATTERY

Instructions



Before installation and use, please read this manual carefully.

Installation and Wiring

* Since each battery doesn't have the same amount of electricity when it left the factory, the time of initial charge or discharge will be different. It is recommended that making a complete charge and discharge before the first time use, improve the efficiency of the built-in battery. 

Application Environment

1. Optimum ambient temperature for long-term use: 10°C-40°C;
2. Working temperature range: -15°C-60°C;
3. Storage temperature: short term (within 1 month): -20°C-40°C;
long term (within 1 year): the battery shall be stored at 10°C-35°C;
4. Relative humidity: not more than 85%;
5. Atmospheric pressure: below altitude 5000;
6. The application place not allowed contain the explosive media. The surrounding medium should not contain corrosive metals, gases and conductive media that damage insulation. It is not allowed have the water vapor and severe mold;
7. The place of application should have facilities to protect against rain, snow, wind, sand and ash.

Attention

1. It is forbidden to use any high-voltage to charge it. Otherwise the BMS components of the battery will be burned out due to the high-voltage, resulting in the failure of overcharge protection. As a result, the battery is overcharged, causing the battery heat out of control and fire hazards. The open circuit voltage of 12V battery pack can not exceed 22V, 24V battery pack can not exceed 44V and 48V battery pack can not exceed 88V. The maximum open circuit voltage of solar panel can not exceed twice of the voltage of battery.
2. Please use a MPPT controller with lithium iron phosphate battery mode. It is strictly prohibited to use any inverter and controller integrated equipment or charge controller which match the lead acid battery to connect the lithium battery, to avoid overcharging of lithium battery and potential fire hazards due to high voltage of solar panel. Or after the battery is fully charged, the lead-acid battery controller continues to charge, which make the BMS of lithium battery cannot work normally.
3. The output must have high-voltage isolation function when using high-voltage inverter and MPPT controller integrated equipment with lithium battery mode. Ensure that the battery is still in a safe state in case of MPPT failure.
4. When the source voltage of the charging terminal is higher than 88V, in order to prevent the failure of the voltage conversion device in the middle and cause overcharging of the battery. The high-voltage circuit breaker with charging protection function must be connected between the charging controller and the battery.

05. 12V battery pack, maximum support 4 battery packs in series, the highest charging voltage of 4 battery packs in series is less than 88V, and the highest charging voltage of 2 battery packs in series is less than 44V. 24V battery pack, maximum support 2 battery packs in series, the highest charging voltage of 2 battery packs in series is less than 88V. 48V battery pack, it is forbidden to use in series. Ensure the batteries are discharged to empty condition or fully charged before connecting them in series. Ensure the voltage of batteries are consistent before connecting the batteries in parallel.
06. It is forbidden to connect the positive and negative poles reversely and short circuit the positive and negative poles of the battery pack; The overload is strictly prohibited.
07. The battery pack should not be used in severe vibration scenarios.
08. It is strictly prohibited to put in water and clean the battery pack, and do not place the product in the outdoor exposed place for a long time to prevent rain or moisture.
09. It is forbidden to use or place the battery at high temperature, otherwise it may cause battery overheating, fire or failure of function and shorter life. If battery is used for a long time, the recommended optimal ambient temperature is 10°C-40°C.
10. The battery should not be placed in the room where any combustible gas or flammable items are stored, and should be used in a clean, dry and ventilated environment.
11. It is strictly prohibited to knock, throw, reverse or trample on the battery pack. It is strictly prohibited to use the battery pack when the appearance is seriously damage (artificial knocking, scraping, falling from height, unauthorized disassembly of the products, etc.).
12. It is strictly forbidden to dump or invert the product.
13. Can connect in parallel up to 2 pcs.
14. During installation and electrical appliances installation, the DC voltage of the solar system may be twice more than the voltage of system (e.g. 12V system with 24V, 24V system with 48V), so it is important to use well-insulated tools.
15. Do not use any measuring tools that are damaged or defective.
16. When you install the system, make sure the fire protection measures do not fail. Do not store the product indoors where any combustible gas or gas mixture is stored.
17. The symbols, logos and labels on the outer surface of the product cannot be modified or removed without notice.
18. All installation work must be carried out under international electrical specifications and related local configurations.
19. Smoking, naked flame and connecting to unprotected lamps are prohibited while operating batteries; Keep away from fire when using.
20. Never cut through the product with nail or other edge tool.
21. Never ship or store the product together with metal.
22. Never throw the product into fire or heating machine to avoid fire, explosion and environment pollution; scrap product should be returned to the supplier and handled by the recycle station.
23. Never use the product under strong static and strong magnetic field, otherwise it will destroy the protecting device.
24. The product should be stored in half SOC. It needs to be charged once if out of use for as long as half a year.
25. Prior to charging, fully check the insulativity, physical condition and ageing status, since breakage and ageing are never allowed.
26. The restricted use current marked on the product is not applicable to the inductive load. Under normal conditions, the instantaneous start current of the inductive load is three times that of the normal operation.

1. Battery Charging

Connect the positive and negative terminals of the battery to the solar panel for charging.

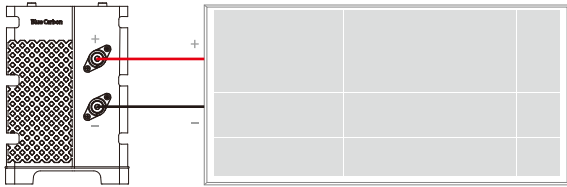

Parallel connection diagram of solar panel

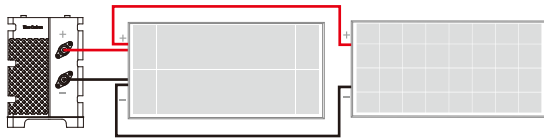

XT90 Terminal Charging Diagram

⚠ Negative XT90 Terminal on the front panel is designed for discharging, not for charging.

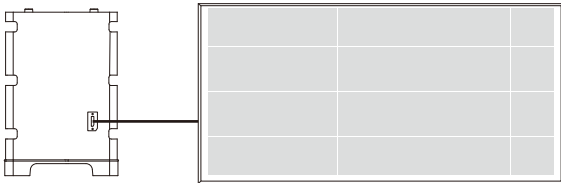

2. The Method to Connect Battery Pack

According to the correct positive and negative poles, connect the inverter or the DC electrical appliance.

12V Battery pack connection diagram

12V Battery pack connected to DC electrical appliances

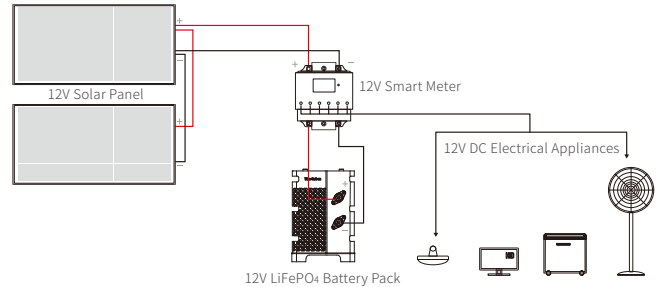

12V Battery pack connected to AC electrical appliances

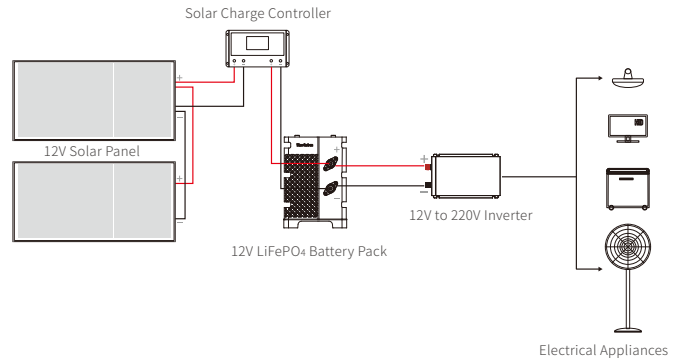

12V Battery pack connection diagram of parallel connection battery pack

It can be used in parallel according to the battery capacity you need, up to two groups.

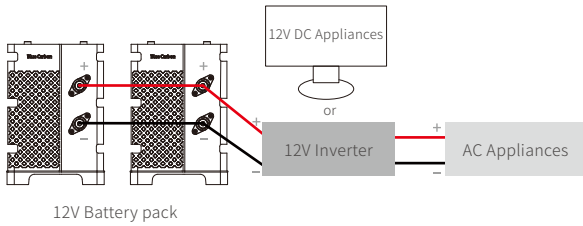

12V Battery pack connection diagram of series connection battery pack

Schematic diagram of 12V series connection into 24V connection

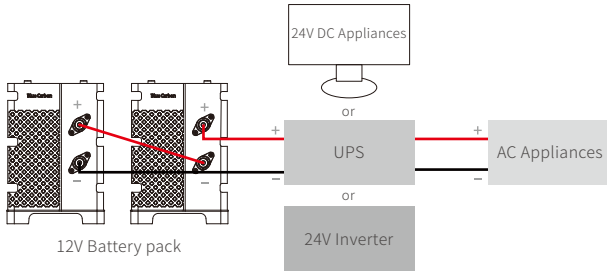

Schematic diagram of 12V series connection into 48V connection

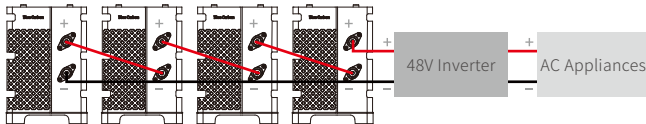

24V Battery pack connection diagram

24V Battery pack connected to DC electrical appliances

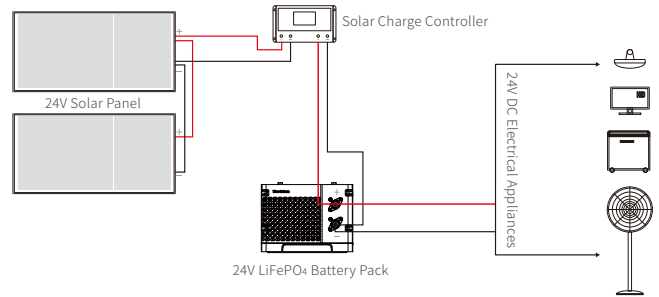

24V Battery pack connected to AC electrical appliances

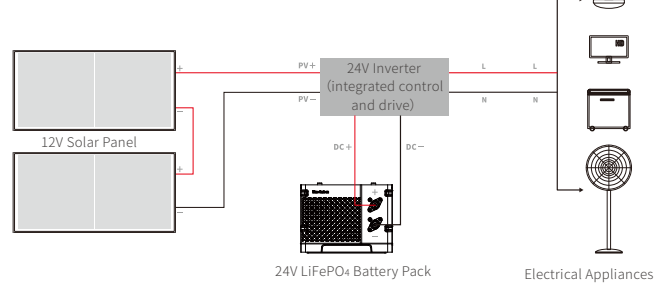

Schematic diagram of 24V series connection into 48V connection

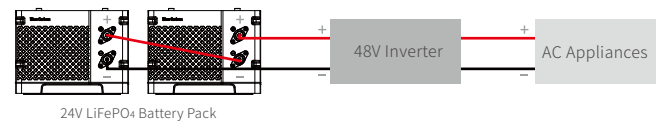

24V Battery pack connection diagram of parallel connection battery pack

It can be used in parallel according to the battery capacity you need, up to two groups.

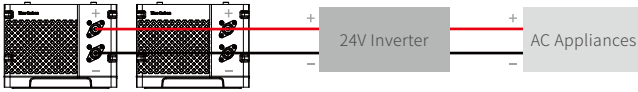

48V Battery pack connection diagram

48V Battery pack connected to AC electrical appliances

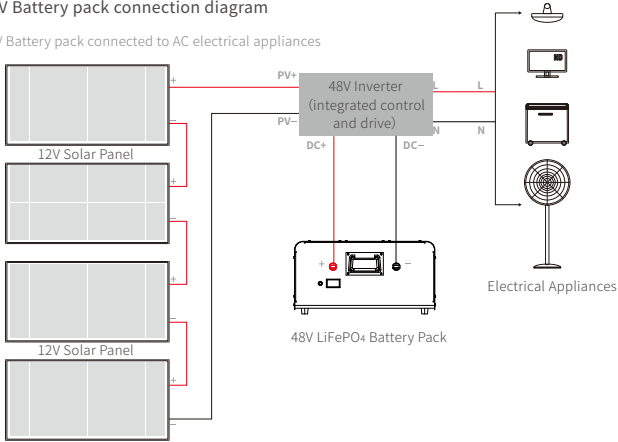

48V Battery pack connection diagram of parallel connection battery pack

48V Battery Pack are not allowed to be used in series!!!

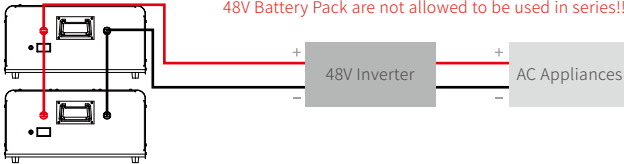

⚠ Never connect in series battery pack with old design control board XT90 Terminal Charging Diagram with battery pack with XT90 Terminal!!!

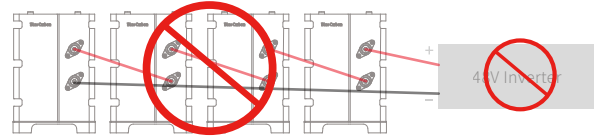

⚠ We recommend using the factory supplied dc appliances to ensure the performance continuity.

1. Chargement de pack batterie

Connectez les bornes positives et négatives sur la batterie avec le panneau pour la charger.



Schéma de connexion parallèle des panneaux solaires



Schéma de chargement de la borne XT90

⚠ Le terminal négatif xt90 sur le panneau avant est conçu pour être déchargé plutôt que chargé.

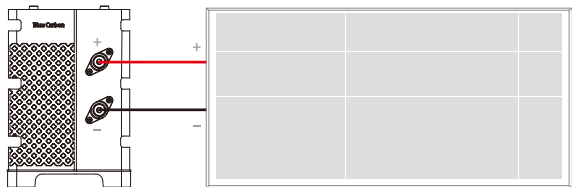
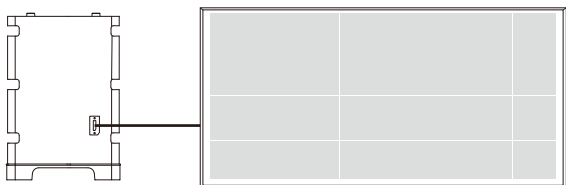

2. Méthode pour connecter le pack batterie

Selon les pôles positifs et négatifs corrects, connectez l'onduleur ou l'appareil électrique CC.

Schéma de connexion du pack batterie 12V

Pack batterie 12V connecté à des appareils électriques DC

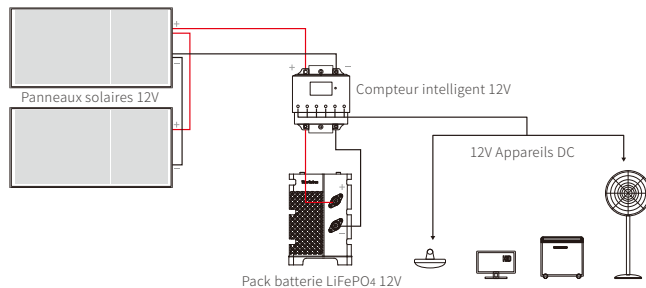

Pack batterie 12V connecté à des appareils électriques AC



Schéma de connexion du pack batterie 12V en parallèle

Il peut être utilisé en parallèle jusqu'à deux groupes, en fonction de la capacité de la batterie dont vous avez besoin.

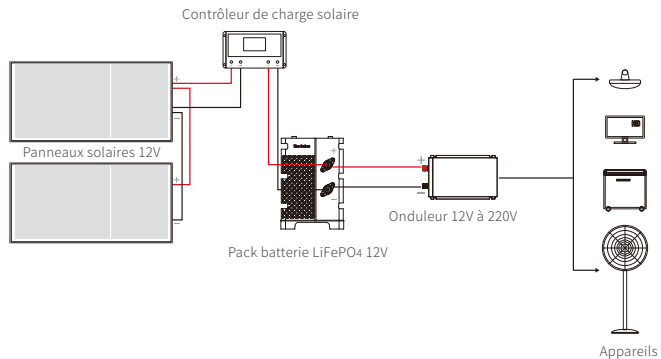
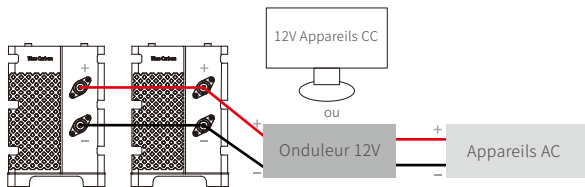

Pack batterie LiFePO4 12V

Schéma de connexion d'un pack batterie 12V en série

Schéma de la connexion en série de 12V en 24V

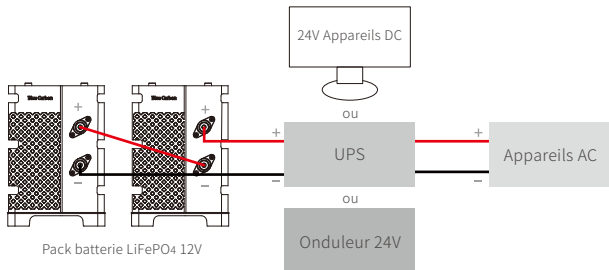

Pack batterie LiFePO4 12V

Schéma de la connexion en série de 12V en 48V



Schéma de connexion du pack batterie

Pack batterie 24V connecté à des appareils électriques CC

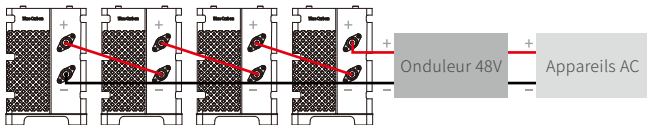
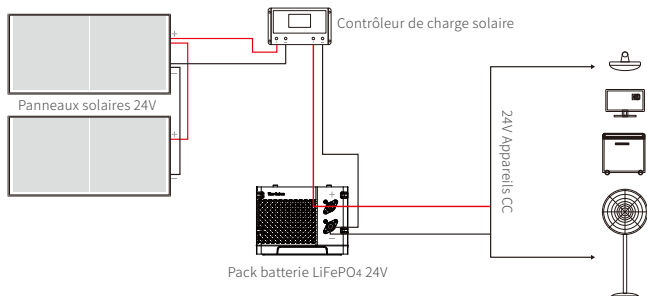

Pack batterie LiFePO4 24V

Pack batterie 24V connecté à des appareils électriques AC

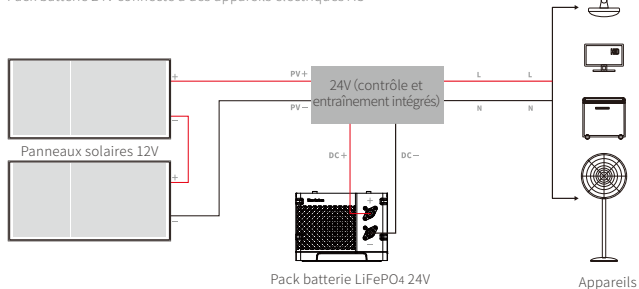

Pack batterie LiFePO4 24V

Schéma de la connexion en série de 24V en 48V

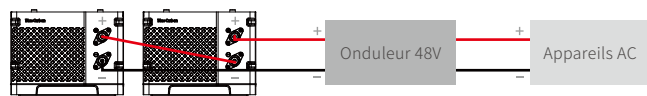

Pack batterie LiFePO4 24V

Schéma de connexion de pack de batteries 24V en parallèle

Il peut être utilisé en parallèle jusqu'à deux groupes, en fonction de la capacité de la batterie dont vous avez besoin.



Schéma de connexion d'un pack batterie 48V

Pack batterie 48V connecté à des appareils électriques AC.

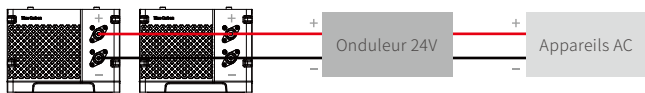

Schéma de connexion du pack batterie 48V de la batterie à connexion parallèle

Les packs batteries 48V ne doivent pas être utilisés en série !!!



⚠ Ne jamais connecter en série un pack batterie ayant un ancien panneau de commande de conception et un pack batterie avec la borne XT90 !!!

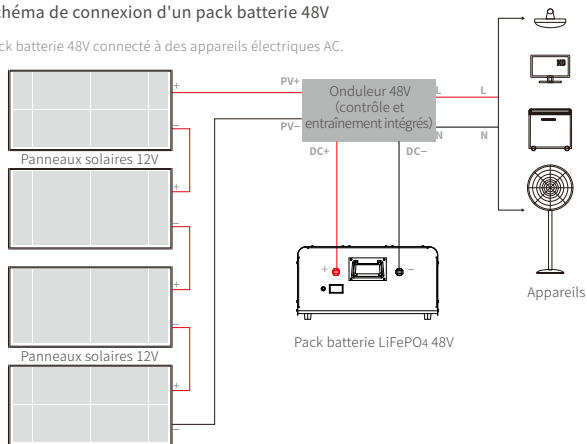
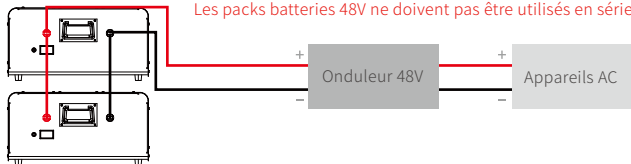
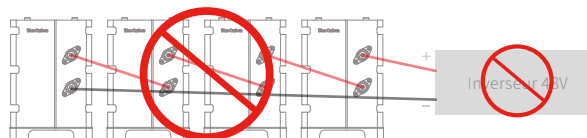

⚠ Nous recommandons d'utiliser les appareils à courant continu fournis par l'usine afin de garantir la continuité des performances.



2. الطريقة لتوصيل البطارية

بنانا على الاقطاب الموجبة والسالبة الصحيحة ، قم بتوصيل المحول أو تطبيق الذي سي الكهربائي

رسم بياني لتوصيلة بطارية 12 فولت

بطارية 12 فولت موصلة باجهزة كهربائية تعمل بالتيار المستمر

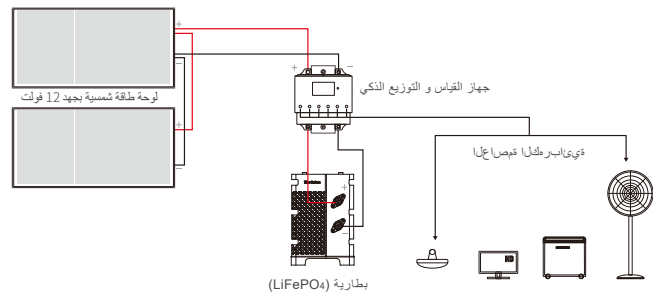

بطارية 12 فولت موصلة باجهزة تعمل بالتيار المتردد (المتناوب)

منظم شحن الطاقة الشمسية

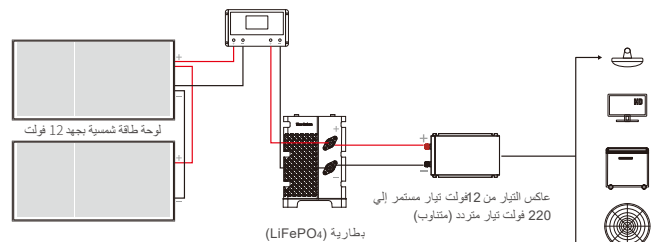

تطبيقات تعمل ب اي سي

1. شحن البطارية

وصل القطبين الموجب والسالب للبطارية بلوح الخلايا الشمسية

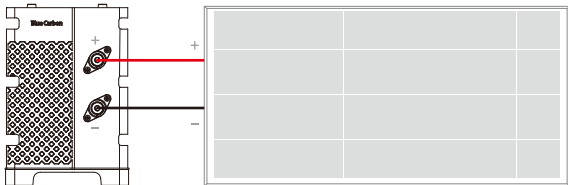

الرسم البياني للتوصيل بالتوازي للخلاية الشمسية

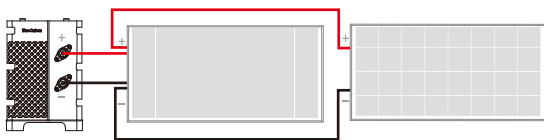

مخطط أقطاب الشحن ل (XT90)

⚠ الأقطاب الأحمر والأسود في اللوحة الأمامية هي الأقطاب الموجب والسالب المخصصة للتفريغ وليس الشحن

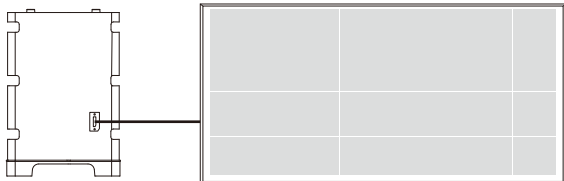

رسم بياني لتوصيلة بطارية 24 فولت

بطارية 24 فولت موصلة باجهزة كهربائية تعمل بالتيار المستمر

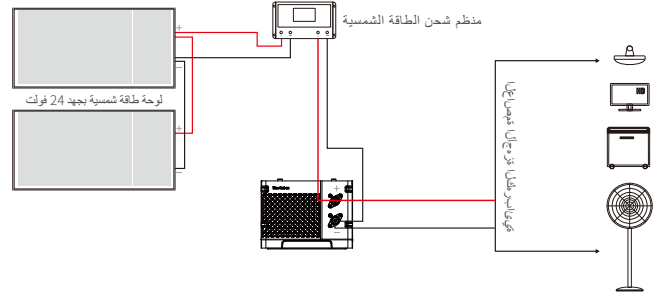

بطارية 24 فولت موصلة باجهزة تعمل بالتيار المتردد (المتناوب)

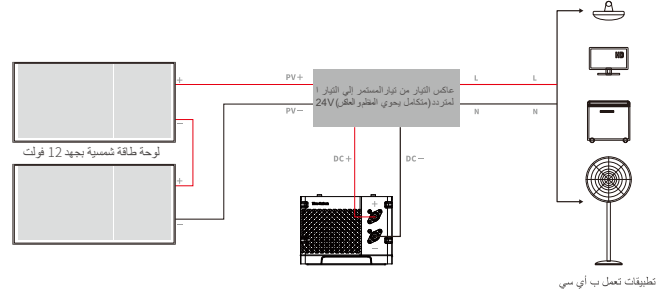

مخطط التوصيل علي التوازي للبطاريات 12 فولت

يمكن توصيل البطاريات علي التوازي حسب الحاجة حتي مجموعتين

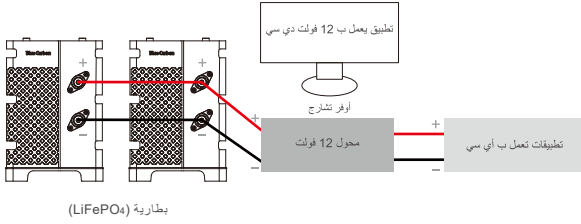

مخطط توصيل علي التوالي لبطاريات 12 فولت

مخطط توصيل بطاريات 12 فولت علي التوالي بنظام 24 فولت

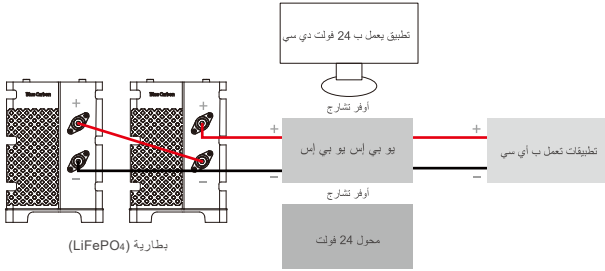

مخطط توصيل بطاريات 12 فولت علي التوالي بنظام 48 فولت

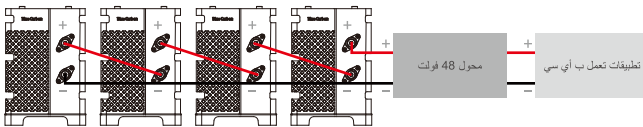

مخطط توصيل بطاريات 24 فولت علي التوالي بنظام 48 فولت

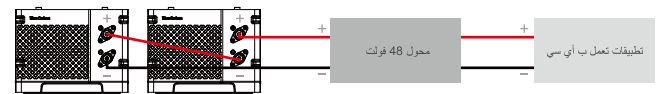

مخطط التوصيل علي التوازي للبطاريات 24 فولت
يمكن توصيل البطاريات علي التوازي حسب الحاجة حتي مجموعتين

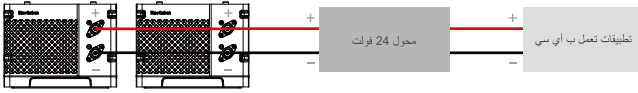

رسم بياني لتوصيلة بطارية 48 فولت
بطارية 48 فولت موصلة بالجزء كبريانية تعمل بالتيار المتردد (متناوب)

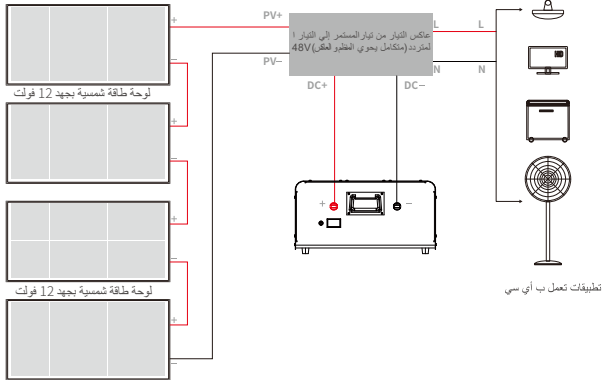

⚠ لا تقم إطلاقاً بتوصيل بطاريات 48 فولت لوحات من التصميم القديم علي التوالي مع بطارية ذات لوحة من التصميم الجديد

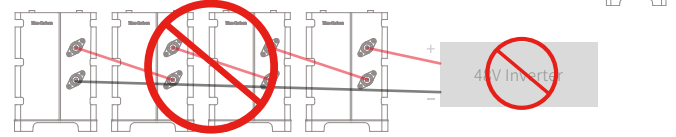

⚠ توصي بشدة باستخدام أجهزة التيار المستمر الموردة من قبل المصنع لضمان الحصول علي أفضل أداء

مخطط التوصيل علي التوازي لبطارية ال 48 فولت
يمنع منعاً باتاً توصيل بطاريات ال 48 فولت علي التوالي



Installation Condition

If this product uses the pv module for charging, the pv module needs installing in light sufficient place, and the pv module did not block by any occlusion or any shadows on the surface, only under this condition can guarantee the working time, otherwise the working time is decreasing in proportion to the photovoltaic module being blocked time.

Storage and Transportation

01. Based on the character of cell, proper environment for transportation of LiFePO₄ battery pack need to be created to protect the battery.
02. If it is not used for the time being, short term (within 1 month) : battery should be stored at -20°C-40°C; long term (within 1 year) : battery should be stored in 10 °C-35 °C the battery should be stored in a dry, clean and well ventilated warehouse, and the fire source should be isolated.

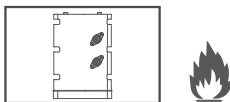

03. During loading of battery, attention must be paid against dropping, turning over and serious stacking.
04. LiFePO₄ battery pack should be properly protected during storage and transportation to maintain a SOC level of about 50% to ensure that no short circuit or liquid enters the LiFePO₄ battery pack or is immersed in a liquid (e.g. water, oil, etc.).

Aftersale Service and Promise

01. Pre-sales, we supply professional production knowledge, details technology information and inspection.
02. Sales: we supply product training.
03. After sales: we supply technical service for all customers. Problems will be replied in 24h.
04. 5 years warranty, free maintenance.

Maintenance

01. When installing in a dusty or seriously hazy area, such as coal yard/mining operation, etc., should clean the surface of the solar panel intermittently.
02. Snow on solar panels should be cleaned intermittently.
03. If bolts ever become loose, tighten them immediately.

Statement

01. The manufacturer will not undertake any loss caused by earthquake, flood, thunder or any other natural disasters, fires not caused by the product itself and theft and damage caused by accidents.
02. The manufacturer will not undertake any loss by customers connecting the product with other unmatched devices or installing in inadequate conditions.
03. The battery pack should not be used under overvoltage. The open circuit voltage of the 12V battery pack cannot exceed 22V; the open circuit voltage of the 24V battery pack cannot exceed 44V; the open circuit voltage of the 48V battery pack cannot exceed 88V. Our company is not responsible for any loss caused by fire or other faults caused by over-voltage use.

* The below damage is not within warranty:

1. Wrong connection between positive and negative.
 2. Overload of electrical appliances.
 3. The outlook is badly broken(because of human damage, scrape, fall down, assemble the products).
 4. Water in (because of put under rain or any other way result in products wet).
 5. If use any other not belong to standard accessories add to the Smart Power result in goes bad (led or other equipment not match the Smart Power).
- When use the products please keep away from the fire, please not through freely.
6. Damage caused by not following the instructions.

